

Horizontal shroud



3D model link

page 3



*iphone/ipad users open this file to view in AR



Product code: **WS-EL-H**

Open bottom shroud



3D model link

page 4



*iphone/ipad users open this file to view in AR



Product code: **WS-EL-OB**

Vertical shroud



3D model link

page 5



*iphone/ipad users open this file to view in AR



Product code: **WS-EL-V**

External Corner shroud



3D model link

page 6



*iphone/ipad users open this file to view in AR



Product code: **WS-EL-EC**

External Angle shroud



3D model link

page 7



*iphone/ipad users open this file to view in AR



Product code: **WS-EL-EA**

Internal Angle shroud



3D model link

page 8



*iphone/ipad users open this file to view in AR

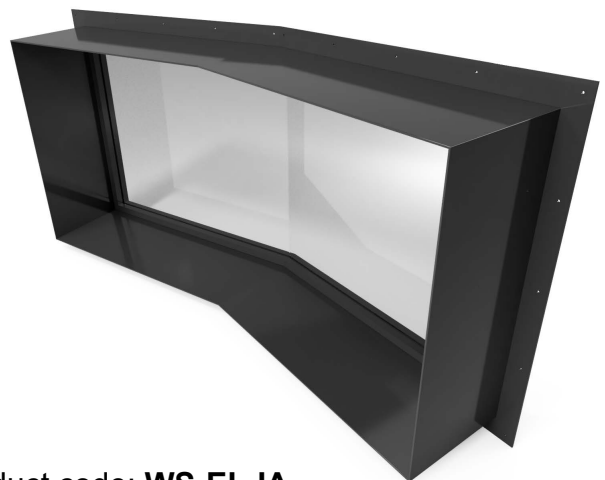

Product code: **WS-EL-IA**



METAL ART & DESIGN
WWW.METAL-ART.COM.AU
DEFINE YOUR SPACE

ORDER FORM

Title
EdgeLine window shroud

Material
aluminium

Rev. Finish
powder coated

Sheet
1/14

Left Corner Shroud



3D model link

page 9



*iphone/ipad users open this file to view in AR



Product code: **WS-EL-LC**

Right Corner Shroud



3D model link

page 10



*iphone/ipad users open this file to view in AR



Product code: **WS-EL-RC**

Arch Top Shroud



3D model link

page 11



*iphone/ipad users open this file to view in AR



Product code: **WS-EL-AT**

Round shroud



3D model link

page 12



*iphone/ipad users open this file to view in AR



Product code: **WS-EL-R**

External Radius Corner



3D model link

page 13



*iphone/ipad users open this file to view in AR



Product code: **WS-EL-ERC**

Internal Radius Corner



3D model link

page 14



*iphone/ipad users open this file to view in AR



Product code: **WS-EL-IRC**



METAL ART & DESIGN
WWW.METAL-ART.COM.AU
DEFINE YOUR SPACE

ORDER FORM

Title
EdgeLine window shroud

Material
aluminium

Rev. Finish
powder coated

Sheet
2/14

Window Shrouds - EdgeLine

-Horizontal Shroud

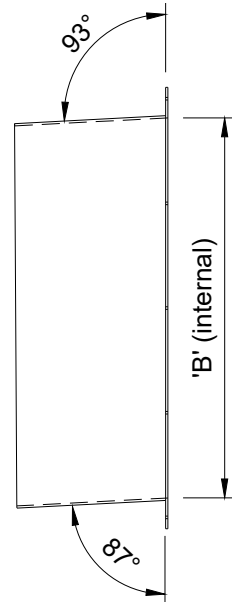
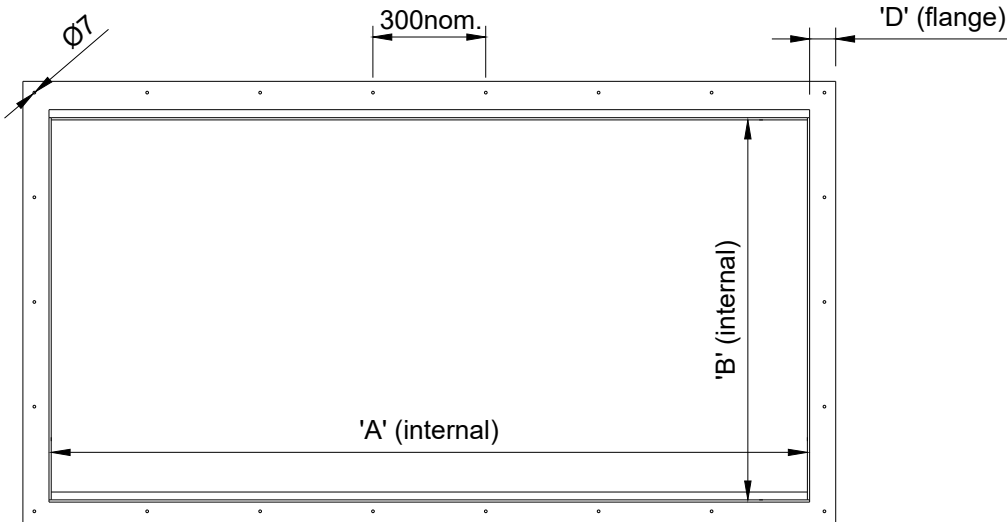
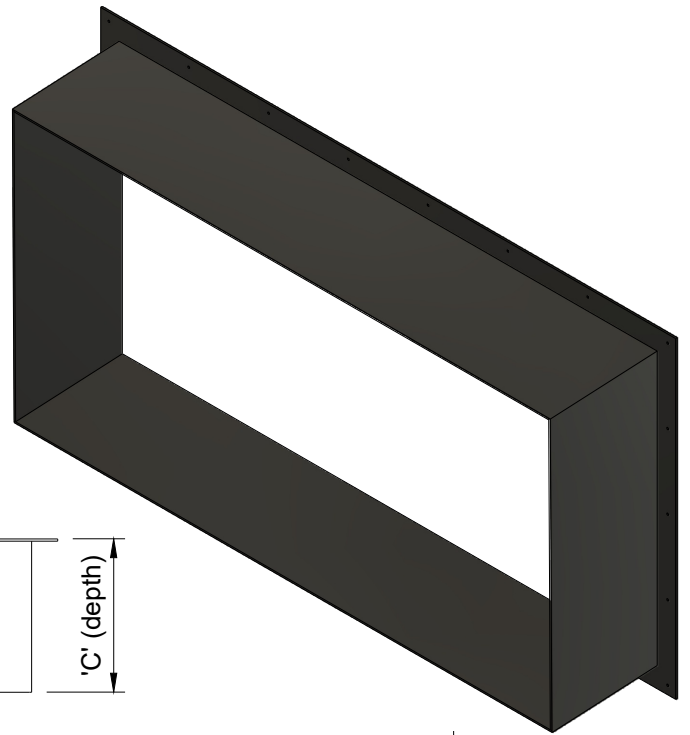

***Recommended fall to top & bottom of shroud is 3°, custom available upon request**

***Standard material thickness 6mm, can be upgraded to 10mm**

***Standard flange width 75mm**

Name		'A' Internal width	
Company		'B' Internal height	
Phone		'C' Overall depth	
Email		'D' Flange width	
Date		Powder Coat colour	
		Quantity	

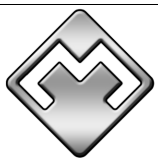

METAL ART & DESIGN
WWW.METAL-ART.COM.AU
DEFINE YOUR SPACE

ORDER FORM

Product code:
WS-EL-H

Material
6mm aluminium

Rev.	Finish	Sheet
	powder coated	3/14

Window Shrouds - EdgeLine

-Open bottom shroud

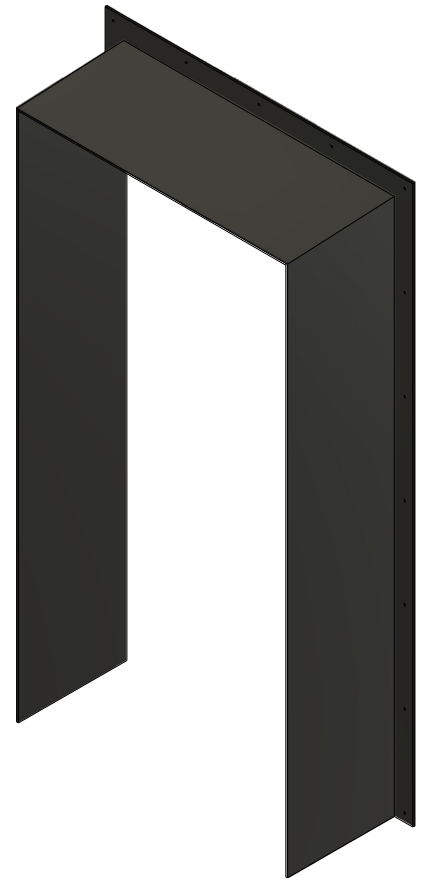
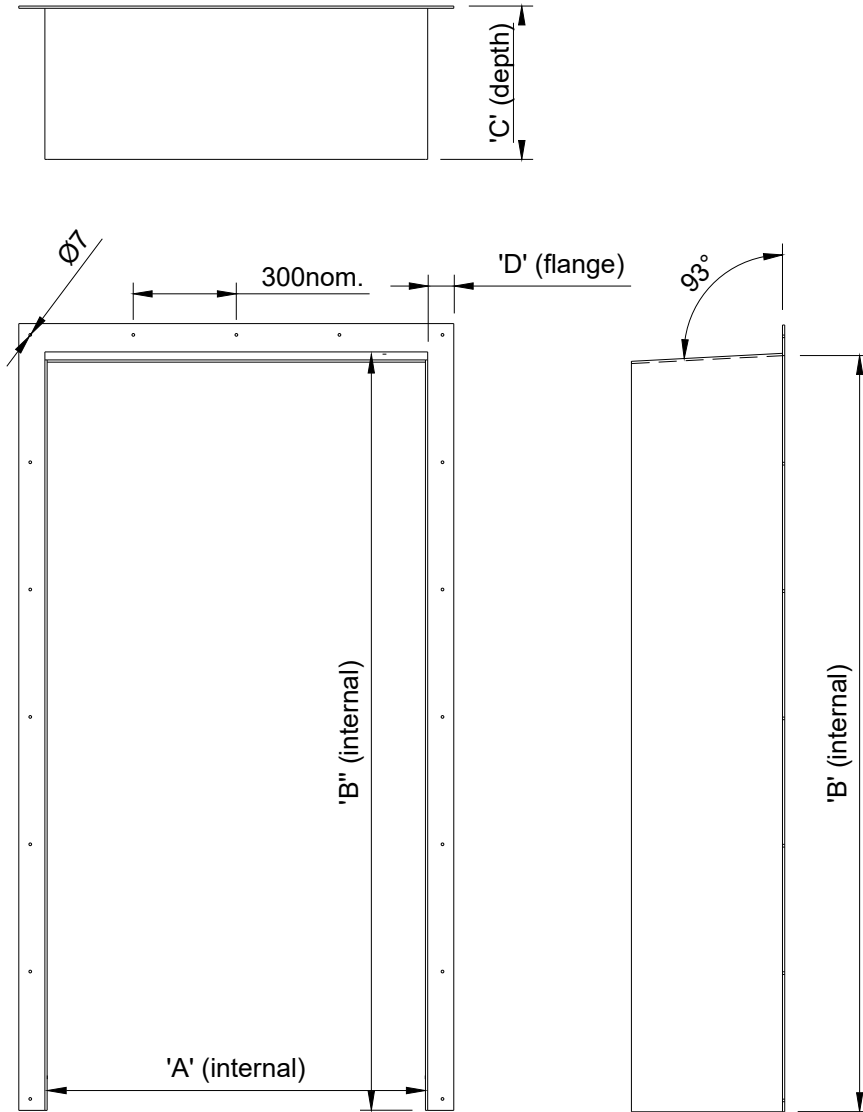

***Recommended fall to top & bottom of shroud is 3°, custom available upon request**

***Standard material thickness 6mm, can be upgraded to 10mm**

***Standard flange width 75mm**

Name		'A' Internal width	
Company		'B' Internal height	
Phone		'C' Overall depth	
Email		'D' Flange width	
Date		Powder Coat colour	
		Quantity	

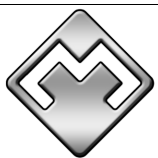

METAL ART & DESIGN
WWW.METAL-ART.COM.AU
DEFINE YOUR SPACE

ORDER FORM

Product code
WS-EL-OB

Material
6mm aluminium

Rev.	Finish	Sheet
	powder coated	4/14

Window Shrouds - EdgeLine

-Vertical Shroud

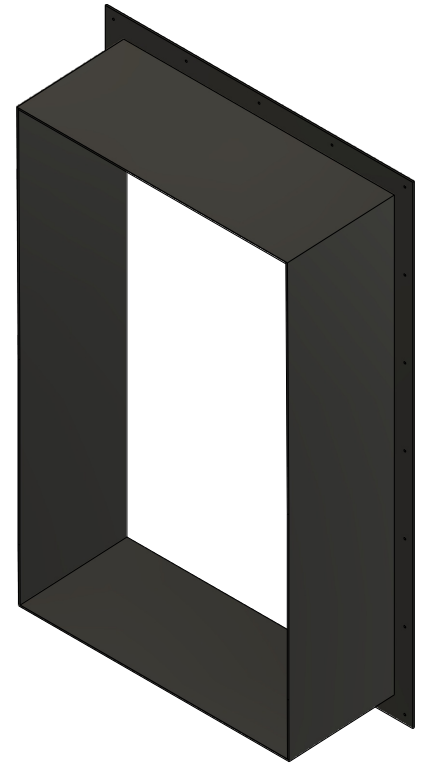
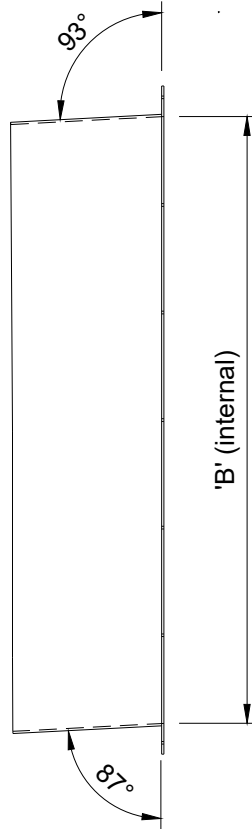
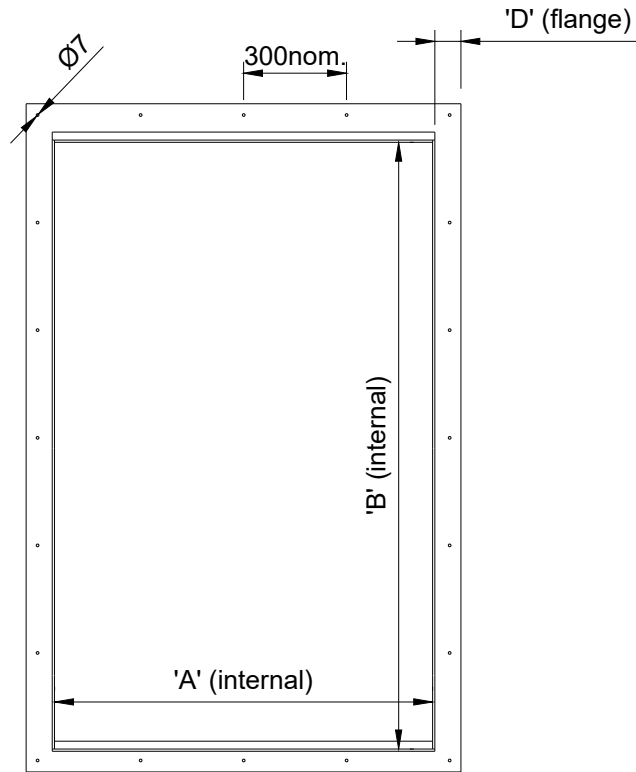
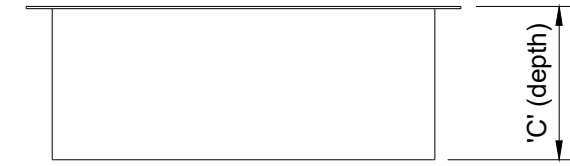

***Recommended fall to top & bottom of shroud is 3°, custom available upon request**

***Standard material thickness 6mm, can be upgraded to 10mm**

***Standard flange width 75mm**

Name		'A' Internal width	
Company		'B' Internal height	
Phone		'C' Overall depth	
Email		'D' Flange width	
Date		Powder Coat colour	
		Quantity	

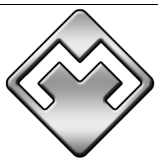

**METAL ART
& DESIGN**
WWW.METAL-ART.COM.AU
DEFINE YOUR SPACE

ORDER FORM

Product code:

WS-EL-V

Material

aluminium

Rev.

Finish

powder coated

Sheet

5/14

Window Shrouds - EdgeLine

-External Corner Shroud

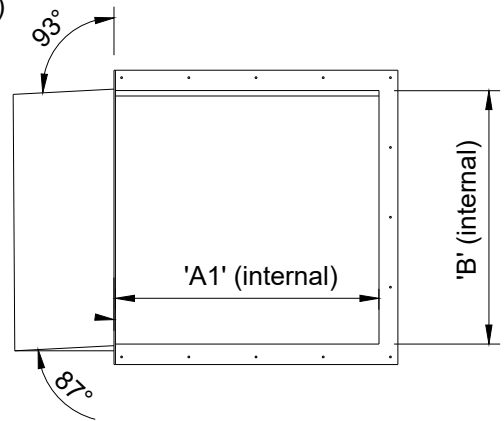
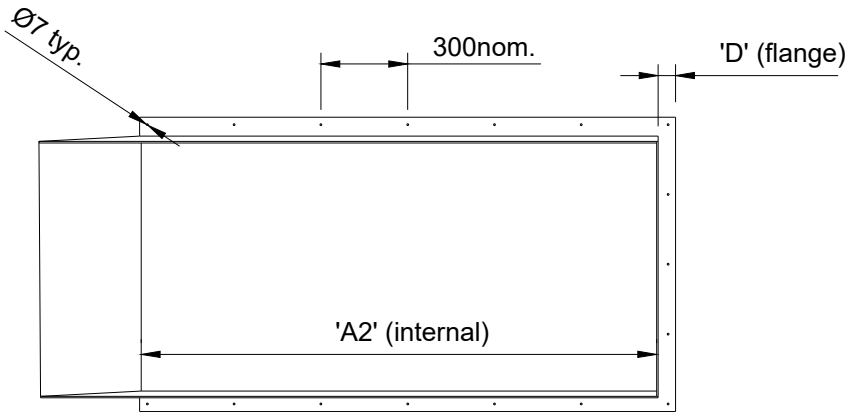
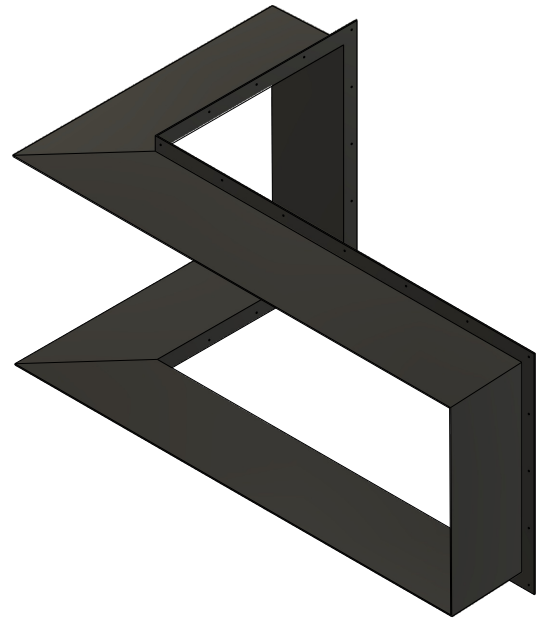
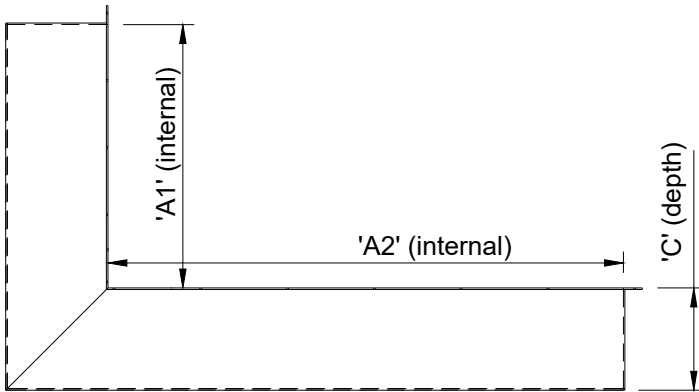

***Recommended fall to top & bottom of shroud is 3°, custom available upon request**

***Standard material thickness 6mm, can be upgraded to 10mm**

***Standard flange width 75mm**

Name		'A1' Internal width	
Company		'A2' Internal width	
Phone		'B' Internal height	
Email		'C' Overall depth	
Date		'D' Flange width	
Quantity		Powder Coat colour	



METAL ART & DESIGN
WWW.METAL-ART.COM.AU
 DEFINE YOUR SPACE

ORDER FORM

Product code:
WS-EL-EC

Material
 aluminium

Rev.	Finish	Sheet
	powder coated	6/14

Window Shrouds - EdgeLine

External angled shroud

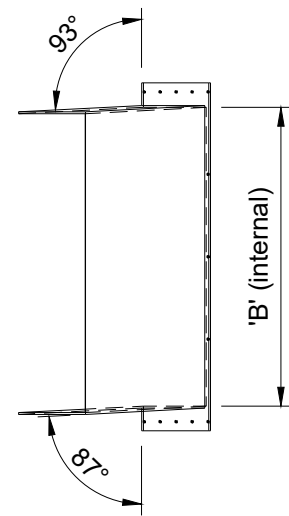
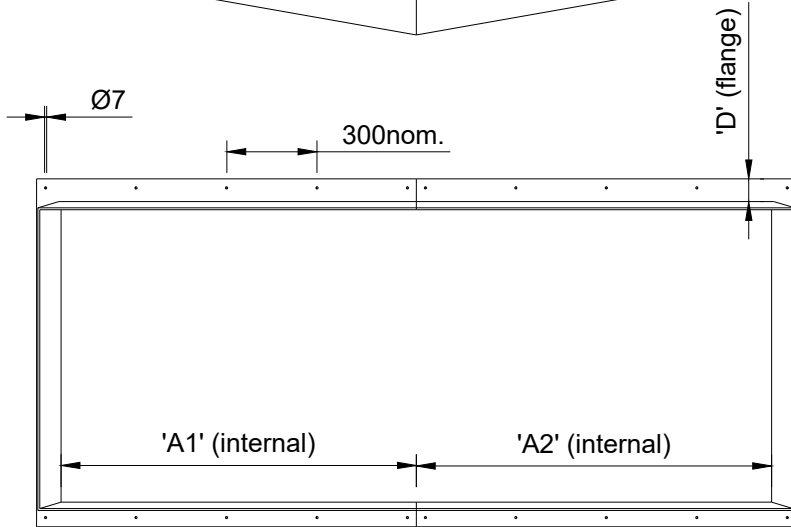
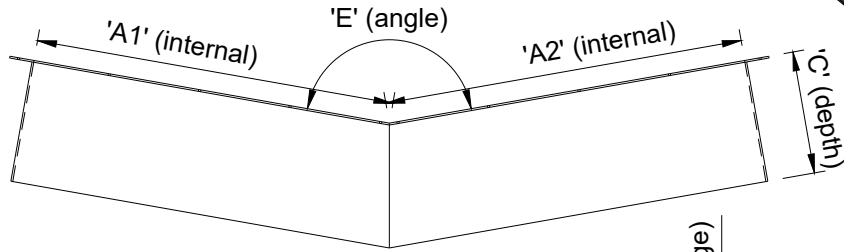
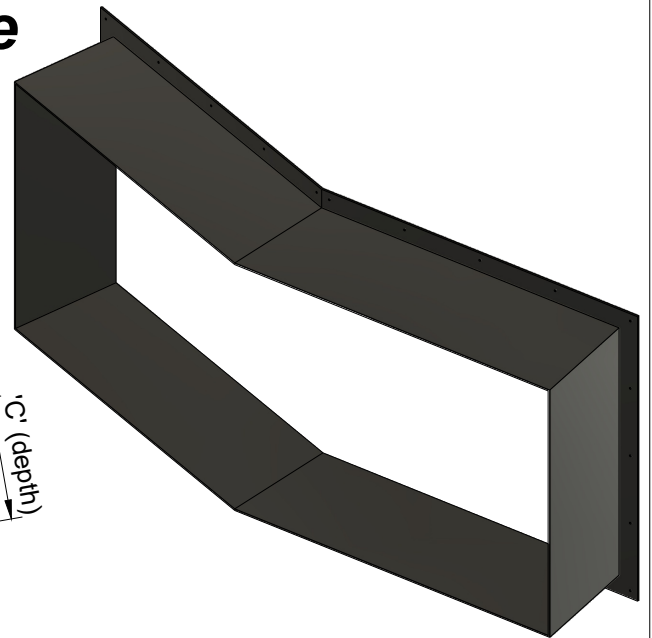

***Recommended fall to top & bottom of shroud is 3°, custom available upon request**

***Standard material thickness 6mm, can be upgraded to 10mm**

***Standard flange width 75mm**

		'A1' Internal width	
Name		'A2' Internal width	
Company		'B' Internal height	
Phone		'C' Overall depth	
Email		'D' Flange width	
Date		'E' angle	
Quantity		Powder Coat colour	



METAL ART & DESIGN
WWW.METAL-ART.COM.AU
 DEFINE YOUR SPACE

ORDER FORM

Product Code:
WS-EL-EA

Material		aluminium	
Rev.	Finish	Sheet	
	powder coated	7/14	

Window Shrouds - EdgeLine

Internal Angle Shroud

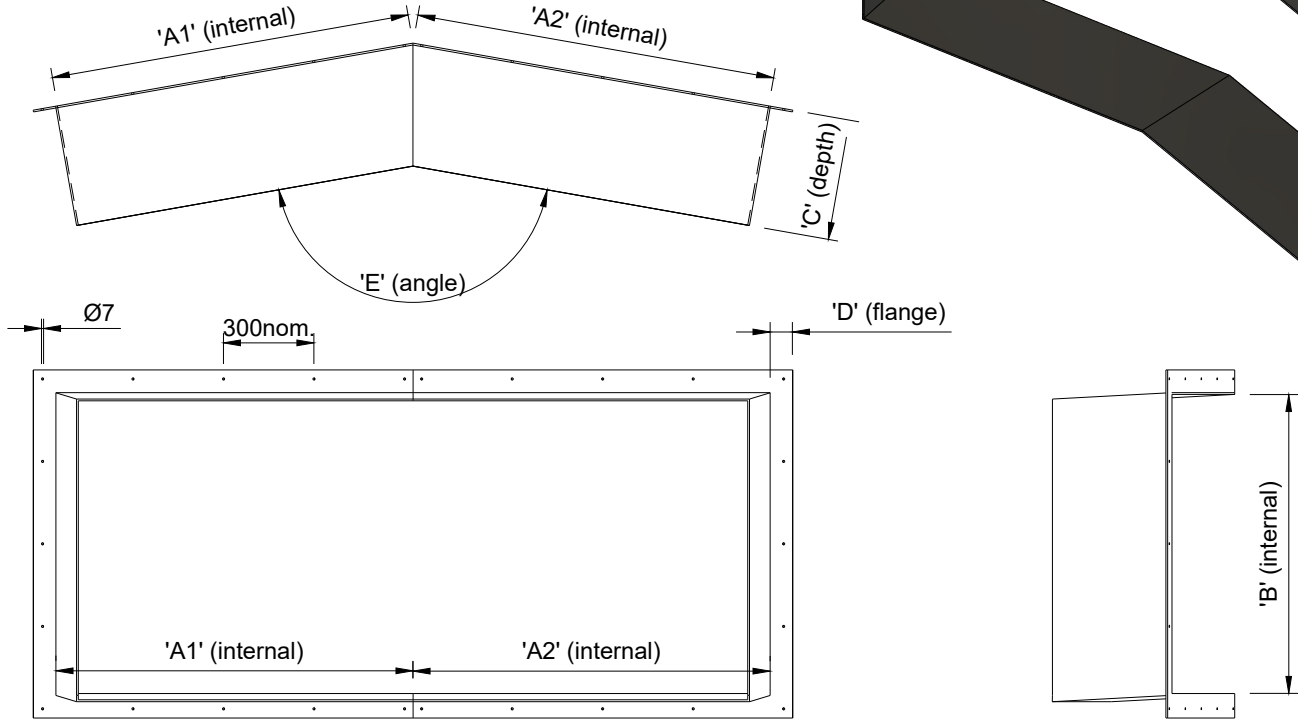
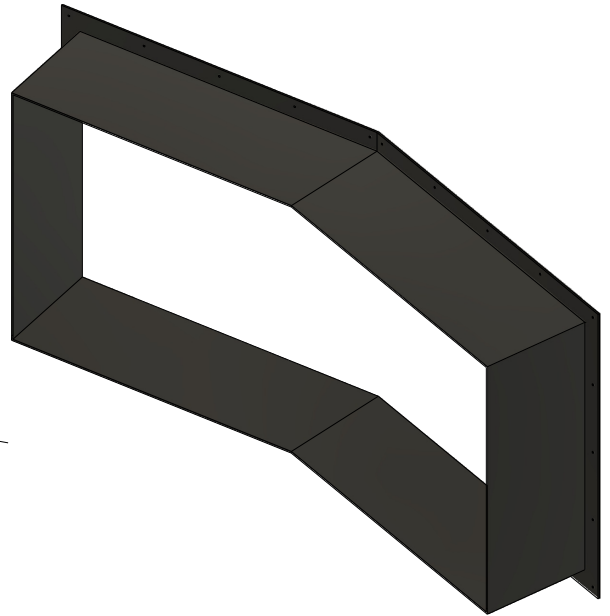

***Recommended fall to top & bottom of shroud is 3°, custom available upon request**

***Standard material thickness 6mm, can be upgraded to 10mm**

***Standard flange width 75mm**

		'A1' Internal width	
Name		'A2' Internal width	
Company		'B' Internal height	
Phone		'C' Overall depth	
Email		'D' Flange width	
Date		'E' angle	
Quantity		Powder Coat colour	

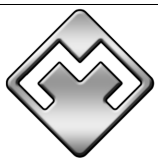

METAL ART & DESIGN
WWW.METAL-ART.COM.AU
 DEFINE YOUR SPACE

ORDER FORM

Product Code:
WS-EL-EA

Material		aluminium	
Rev.	Finish	Sheet	
	powder coated	8/14	

Window Shrouds - EdgeLine

-Left Corner Shroud

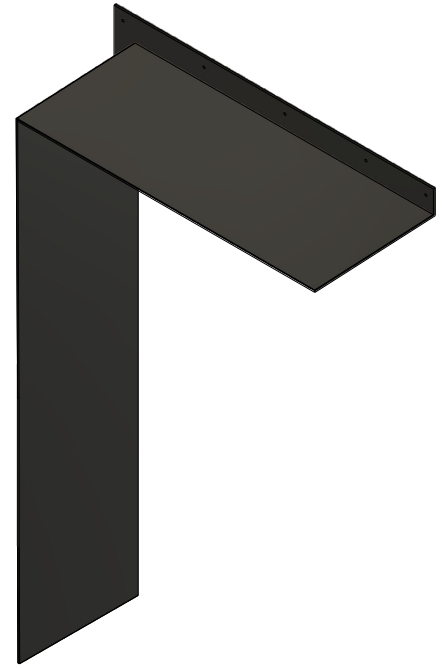
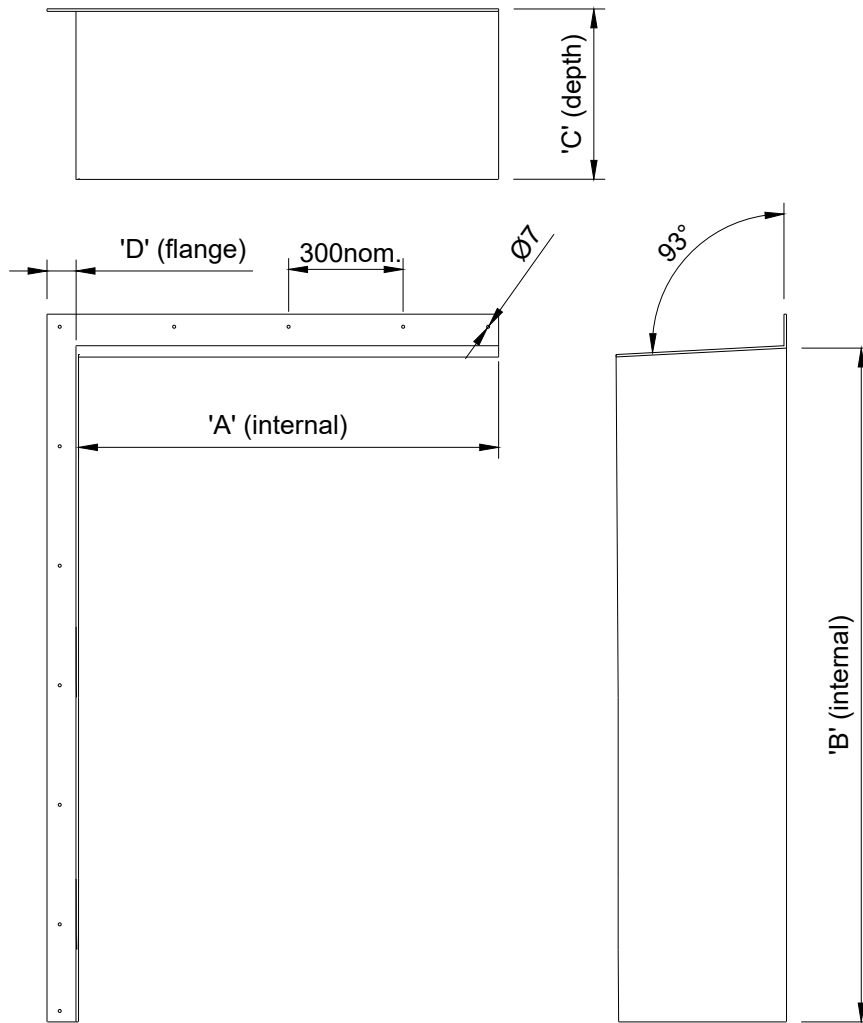

***Recommended fall to top & bottom of shroud is 3°, custom available upon request**

***Standard material thickness 6mm, can be upgraded to 10mm**

***Standard flange width 75mm**

Name		'A' Internal width	
Company		'B' Internal height	
Phone		'C' Overall depth	
Email		'D' Flange width	
Date		Powder Coat colour	
		Quantity	

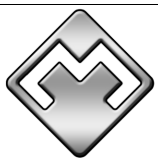

**METAL ART
& DESIGN**
WWW.METAL-ART.COM.AU
DEFINE YOUR SPACE

ORDER FORM

Product code:
WS-EL-LC

Material
aluminium

Rev.	Finish	Sheet
	powder coated	9/14

Window Shrouds - EdgeLine

-Right Corner Shroud

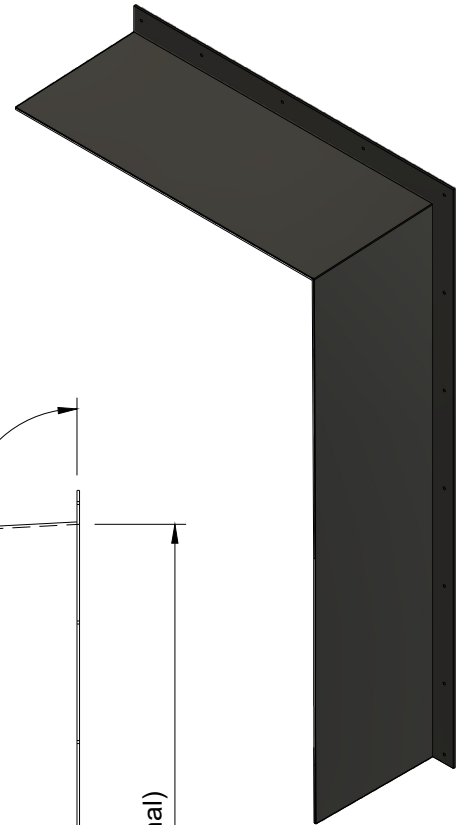
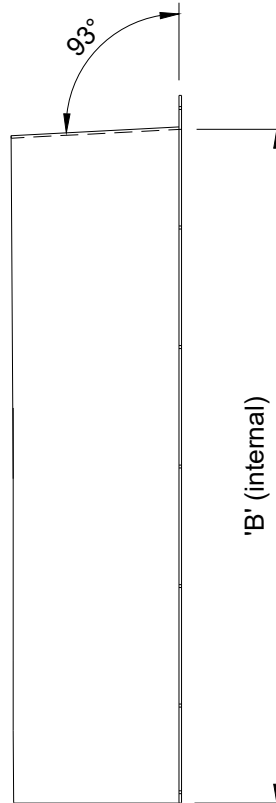
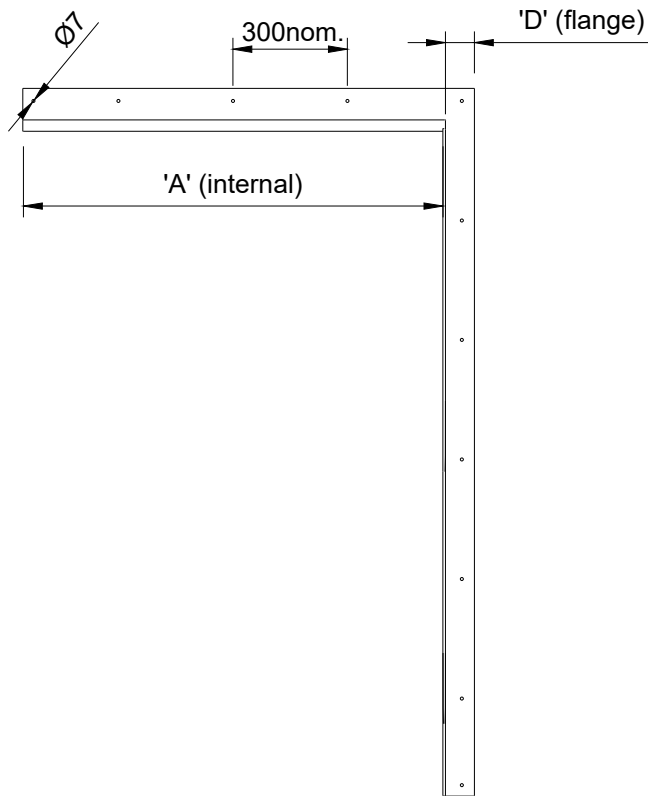
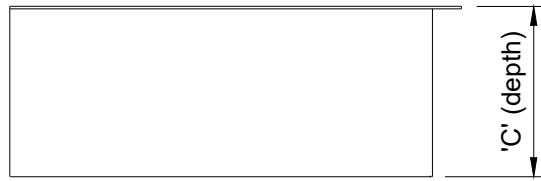

***Recommended fall to top & bottom of shroud is 3°, custom available upon request**

***Standard material thickness 6mm, can be upgraded to 10mm**

***Standard flange width 75mm**

Name		'A' Internal width	
Company		'B' Internal height	
Phone		'C' Overall depth	
Email		'D' Flange width	
Date		Powder Coat colour	
		Quantity	



**METAL ART
& DESIGN**
WWW.METAL-ART.COM.AU
DEFINE YOUR SPACE

ORDER FORM

Product code

WS-EL-RC

Material

aluminium

Rev.

Finish

powder coated

Sheet

10/14

Window Shrouds - EdgeLine

-Arch top shroud

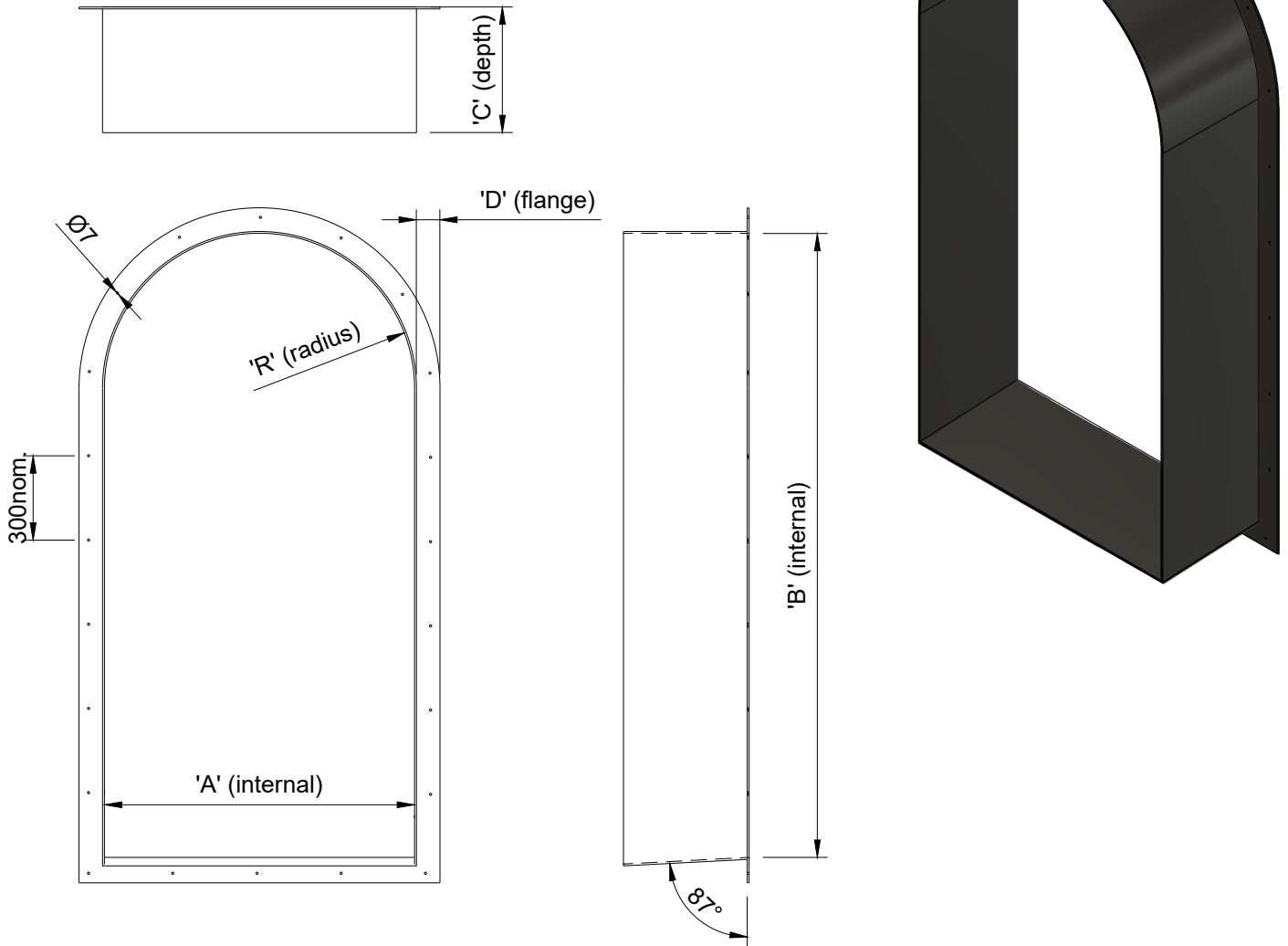

***Recommended fall to top & bottom of shroud is 3°, custom available upon request**

***Standard material thickness 6mm, can be upgraded to 10mm**

***Standard flange width 75mm**

Name		'A' Internal width	
Company		'B' Internal height	
Phone		'C' Overall depth	
Email		'R' Radius	
Date		Powder Coat colour	
		Quantity	

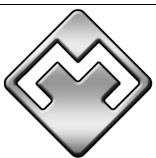

**METAL ART
& DESIGN**
WWW.METAL-ART.COM.AU
DEFINE YOUR SPACE

ORDER FORM

Product code:

WS-EL-AT

Material

aluminium

Rev.

Finish

powder coated

Sheet

11/14

Window Shrouds - EdgeLine

- Round Shrou

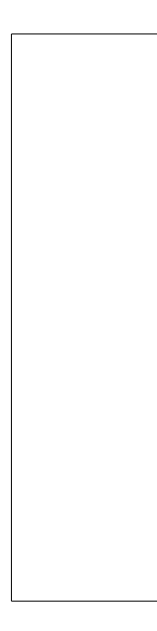
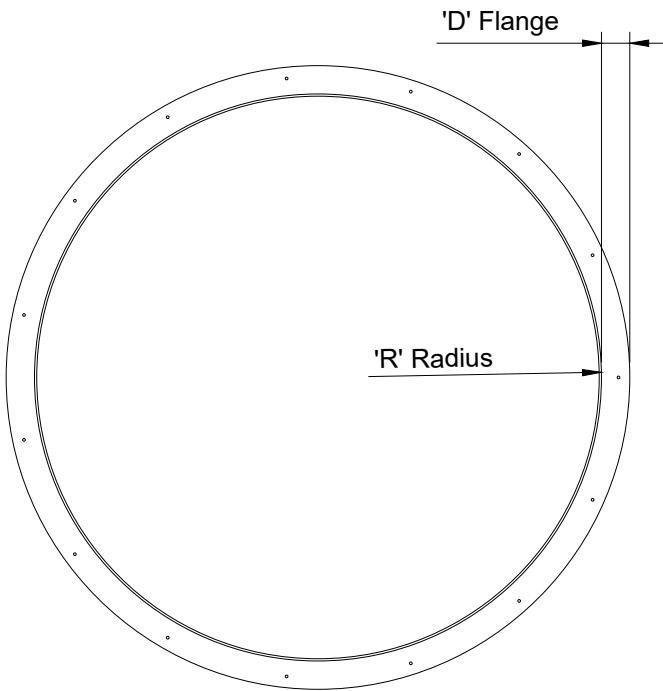
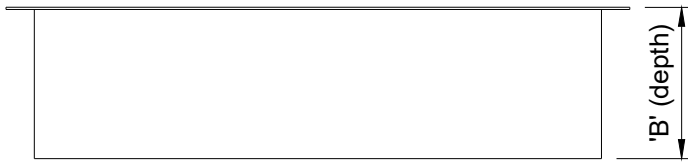

***Recommended fall to top & bottom of shroud is 3°, custom available upon request**

***Standard material thickness 6mm, can be upgraded to 10mm**

***Standard flange width 75mm**

Name		'R' Radius	
Company		'B' Depth	
Phone		'D' Flange width	
Email		Powder Coat colour	
Date		Quantity	

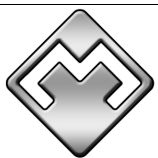

**METAL ART
& DESIGN**
WWW.METAL-ART.COM.AU
DEFINE YOUR SPACE

ORDER FORM

Product code:
WS-EL-R

Material
aluminium

Rev.	Finish	Sheet
	powder coated	12/14

Window Shrouds - EdgeLine

-External Radius Corner Shroud

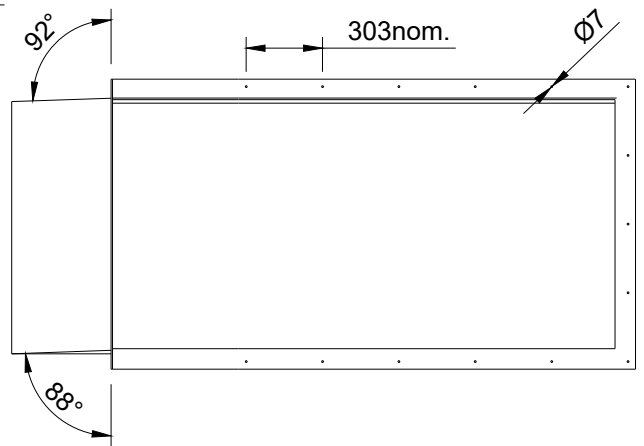
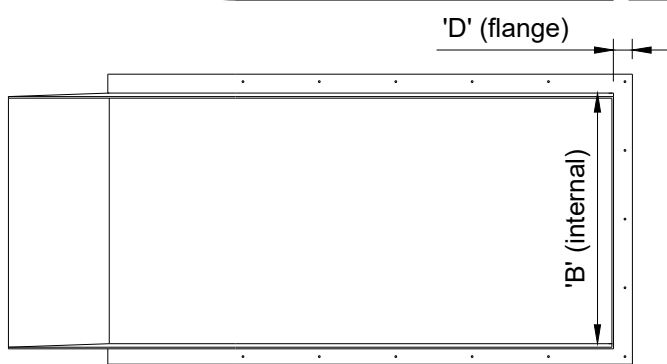
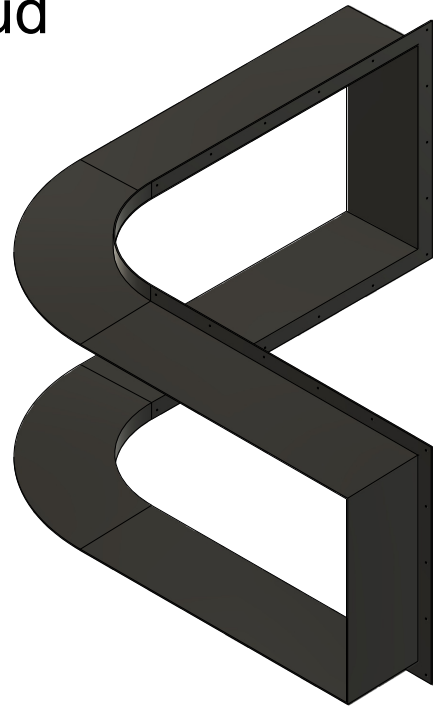
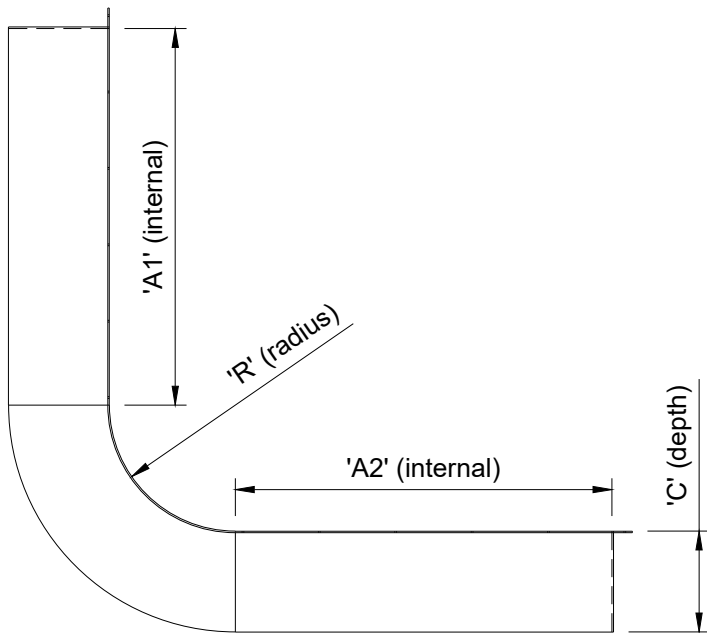

***Recommended fall to top & bottom of shroud is 3°, custom available upon request**

***Standard material thickness 6mm, can be upgraded to 10mm**

***Standard flange width 75mm**

		'A1' Internal width	
Name		'A2' Internal width	
Company		'B' Internal height	
Phone		'C' Overall depth	
Email		'D' Flange width	
Date		'R' Radius	
Quantity		Powder Coat colour	



METAL ART & DESIGN
WWW.METAL-ART.COM.AU
 DEFINE YOUR SPACE

ORDER FORM

Product Code:

WS-EL-ERC

Material

aluminium

Rev.

Finish

powder coated

Sheet

13/14

Window Shrouds - EdgeLine

-Internal Radius Corner shroud

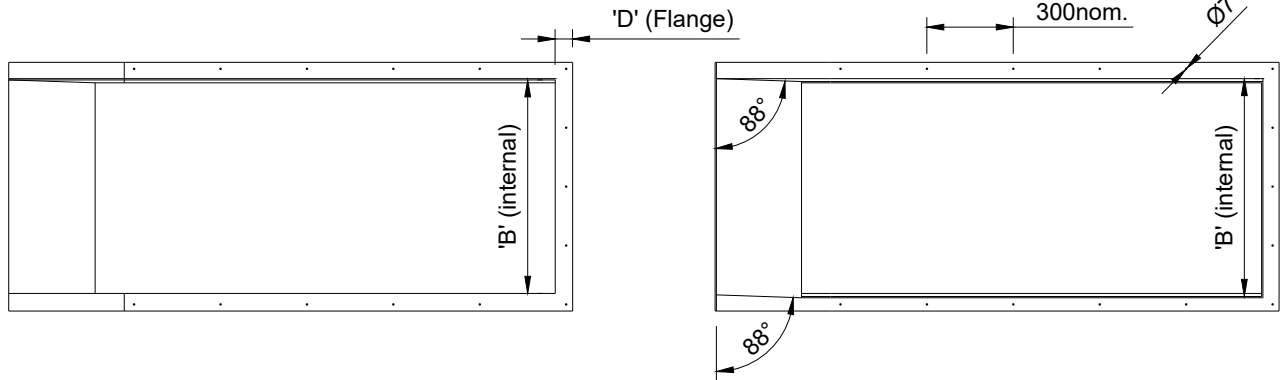
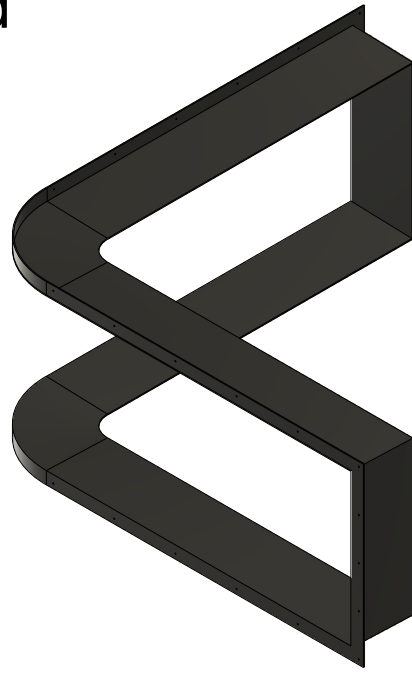
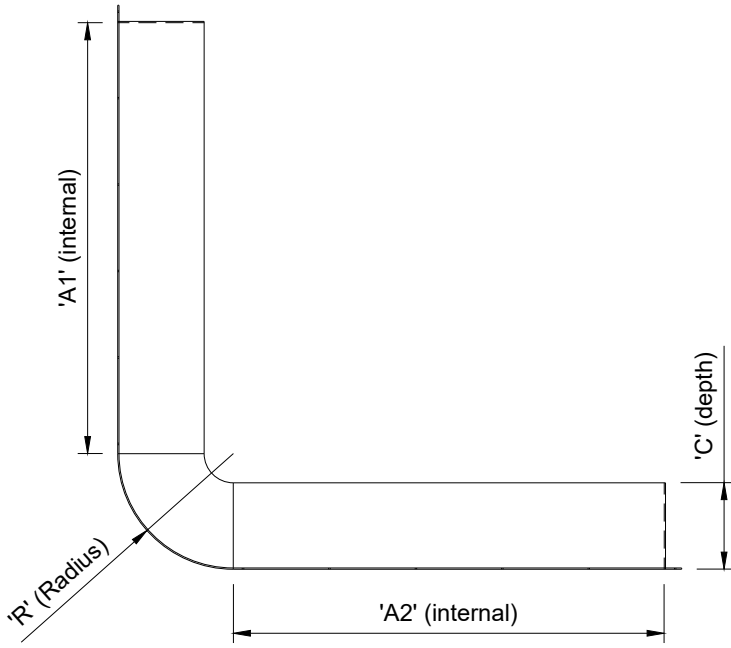

***Recommended fall to top & bottom of shroud is 3°, custom available upon request**

***Standard material thickness 6mm, can be upgraded to 10mm**

***Standard flange width 75mm**

		'A1' Internal width	
Name		'A2' Internal width	
Company		'B' Internal height	
Phone		'C' Overall depth	
Email		'D' Flange width	
Date		'R' Radius	
Quantity		Powder Coat colour	



METAL ART & DESIGN
WWW.METAL-ART.COM.AU
 DEFINE YOUR SPACE

ORDER FORM

Product Code:
WS-EL-IRC

Material
 aluminium

Rev.	Finish	Sheet
	powder coated	14/14